

WARNING DEATH MAY OCCUR IF TANK IS ENTERED WITHOUT PROPER EQUIPMENT

NOTE: SEE INNER WALL PHOTO ON THE "EXCLUSIVELY AT SKAW'S" PAGE.

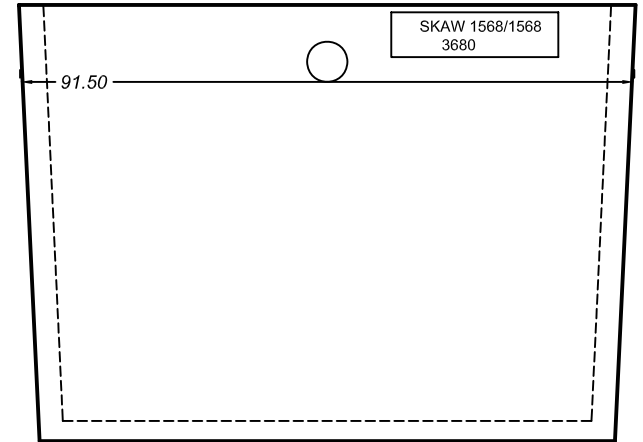

OUTLET END VIEW OF TANK

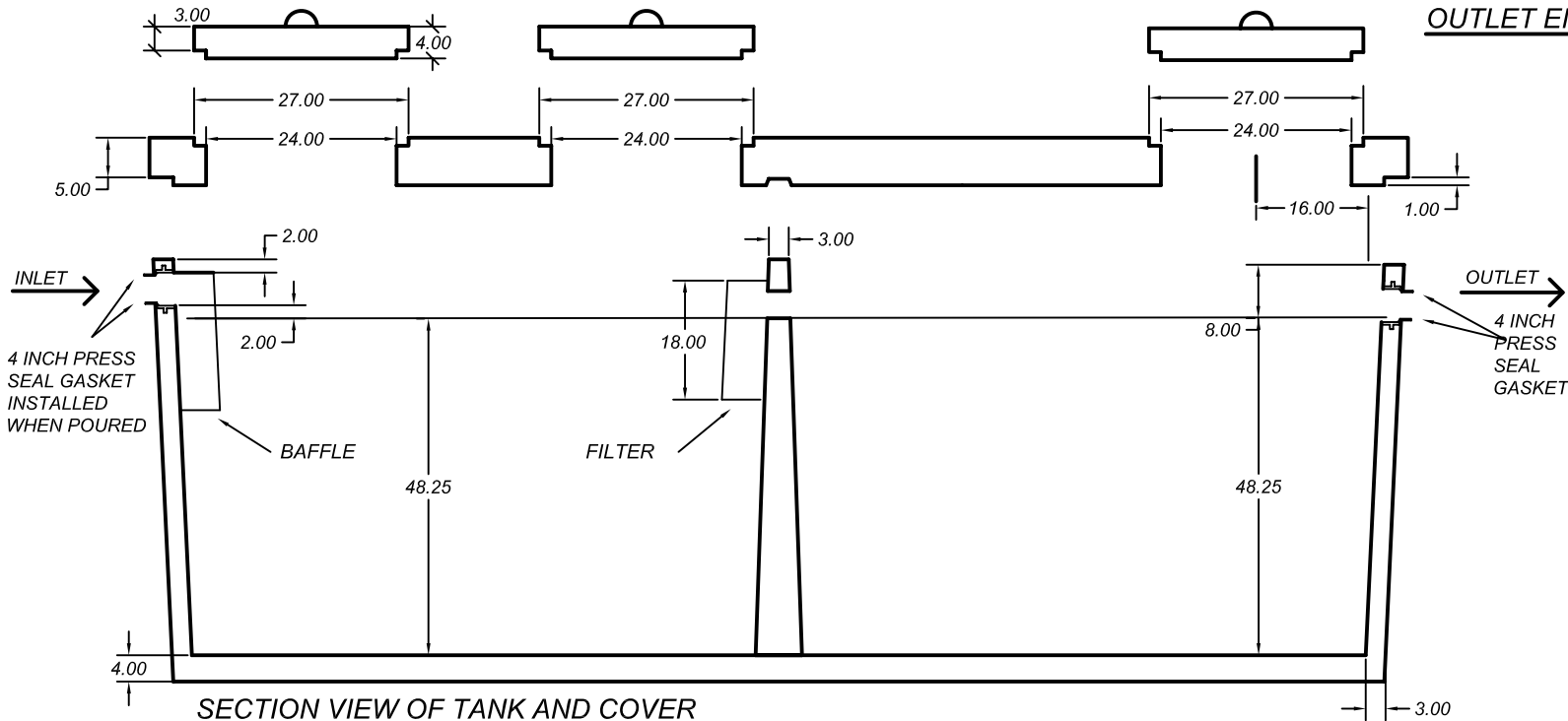

SECTION VIEW OF TANK AND COVER

Model Number: **1568 / 1568**

Approved for: SEPTIC/SEPTIC, SEPTIC/PUMP, SEPTIC/SIPHON OR HOLDING

Weight	Inlet Dim.	Outlet Dim.	Liq. Depth	Gal. / In.	Nom. Cap.
21,800 lbs.	54"	52"	48.25"	32.49	1568 gal.

**SKAW PRE-CAST**

26255 105th Street, New Auburn  
Wisconsin 54757  
www.skawprecast.com

Phone: (715) 967-2277  
Toll Free: 1-800-924-8625  
Fax: (715) 967-2707

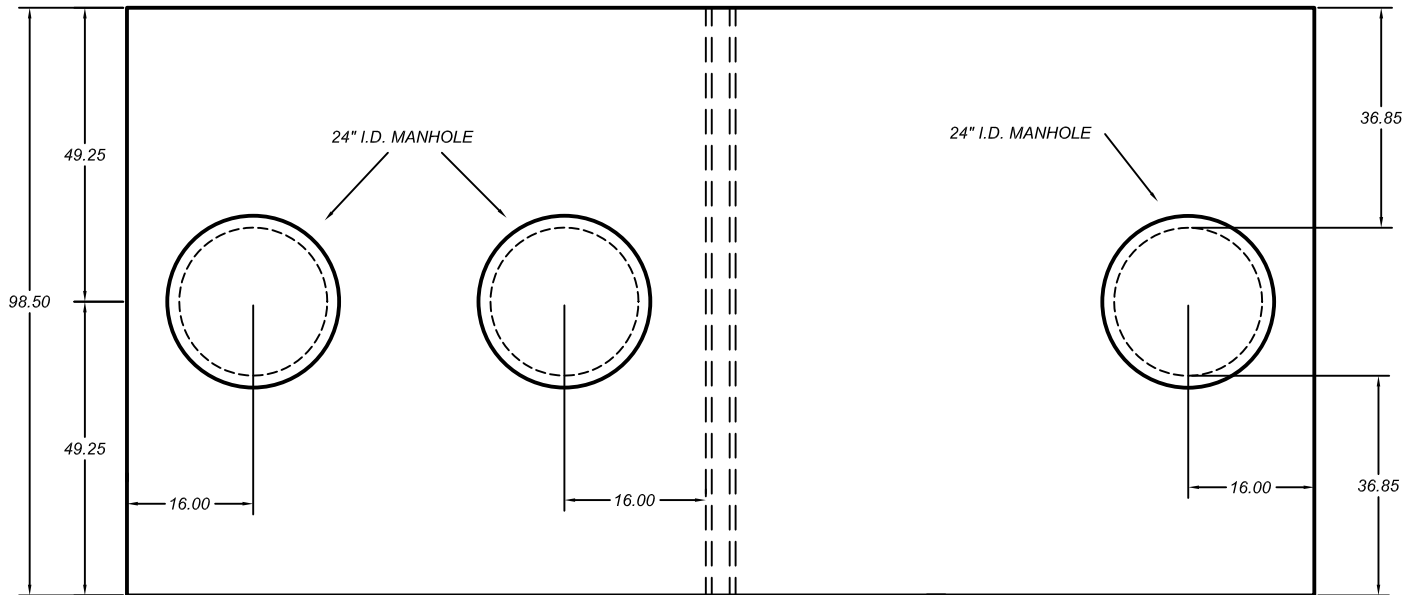

TOP VIEW OF COVER

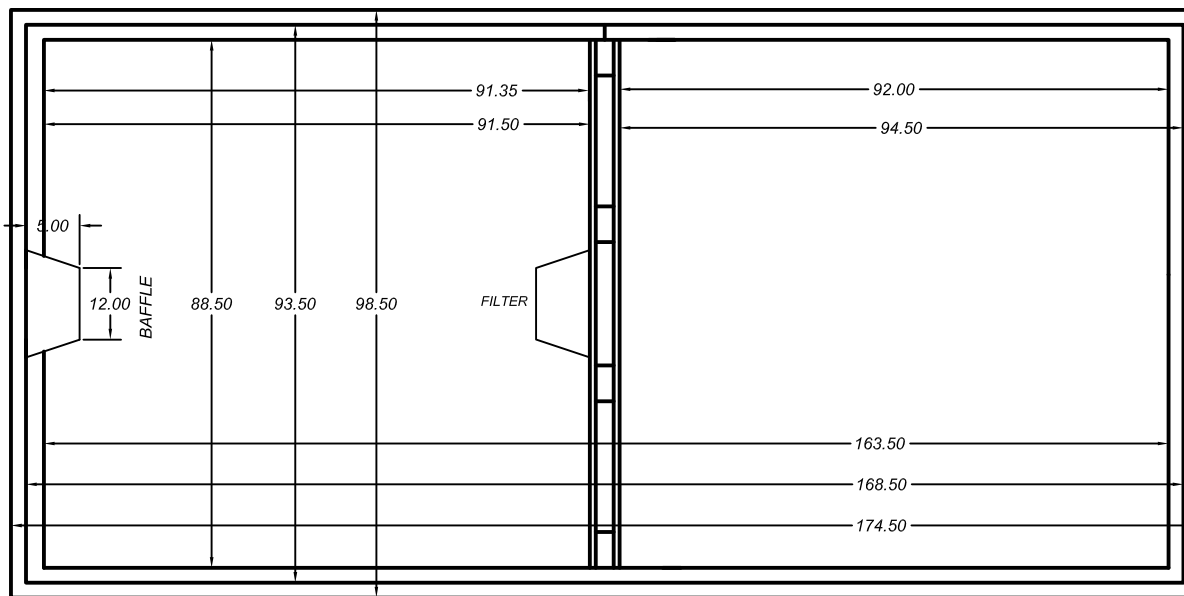

TOP VIEW OF TANK (TAPERED)

Model Number: **1568 / 1568**

Approved for: SEPTIC/SEPTIC, SEPTIC/PUMP, SEPTIC/SIPHON OR HOLDING

Weight	Inlet Dim.	Outlet Dim.	Liq. Depth	Gal. / In.	Nom. Cap.
13,050 lbs.	54"	52"	48.25"	32.49	1568 gal.

**SKAW PRE-CAST**

26255 105th Street, New Auburn  
Wisconsin 54757  
[www.skawprecast.com](http://www.skawprecast.com)

Phone: (715) 967-2277  
Toll Free: 1-800-924-8625  
Fax: (715) 967-2707